



**AGENDA**

**City of Milton**

**Parks & Recreation Commission**

**Monday, November 18, 2019**

**6:00 p.m.**

**MILTON CITY HALL**

**Conference Room**

**710 S. Janesville Street**

**1. Call To Order**

**2. Approve Agenda**

**3. Approval Of Minutes - September 16, 2019**

Documents:

[PARKS AND RECREATION COMMISSION MINUTES 09-16-19.PDF](#)

**4. Update, Discussion, And Possible Action On The Veterans Park Pavilion**

**5. 2019 Work Plan**

**a. *Update On Story Gardens Project***

**6. Discussion And Possible Action On Permanent Installation Of Story Walk Book Holders Around The Trail At Crossridge Park**

Documents:

[BD13902 17A MILTON PUBLIC LIBRARY ASHLEE KUNKEL 1142019.PDF](#)  
[BD13903 17W MILTON PUBLIC LIBRARY ASHLEE KUNKEL 11042019.PDF](#)  
[STORYWALK SOLUTIONS ALUMINUM POST FRAME ANGLED.PDF](#)  
[STORYWALK SOLUTIONS WOOD POST FRAME ANGLED.PDF](#)

**7. Discussion And Possible Action On Operations At The Air Products Ice Rink**

**8. Discussion And Possible Action On 2020 Work Plan**

Documents:

[DRAFT 2020 PARKS AND RECREATION COMMISSION WORK PLAN.PDF](#)

**9. General Items**

**10. Set Next Meeting Date**

**11. Motion To Adjourn**

\*\*Please note that upon reasonable notice, at least 48 hours in advance, efforts will be made to accommodate the needs to disabled individuals through appropriate aids and services. For

additional information to request this service, please contact the City Clerk's office at 868-6900, 710 S. Janesville Street, Milton, WI 53563.

Notice is hereby given that a majority of the Common Council may be present at this meeting at the above mentioned date and time to gather information about a subject over which they have decision-making responsibility. This constitutes a meeting of the City Council pursuant to State ex rel. Badke v. Greendale Village Bd., 173 Wis. 2d 553, 494 N.W. 2d 408 (1993) and must be noticed as such, although the City Council will not take any formal action at this meeting.

Posted by: Leanne Schroeder, November 15, 2019

**City of Milton  
Parks & Recreation Commission  
September 16, 2019**

**Call To Order**

Chairperson Ryan Peterson called the September 16, 2019 meeting of the Parks & Recreation Commission to order at 6:03 p.m.

Present: Chairperson Ryan Peterson, Andrea Christianson, Annette Smith, David Snow, Ty Knudsen, Lee Ann Hare, James Bostwick, and Karen Reed.

Also Present: Dick Fry, Jarret Goodman, Public Works Director Howard Robinson, and Administrative Services Director Inga Cushman.

**Approve Agenda**

Comm. Bostwick motioned to approve the agenda. Comm. Smith seconded, and the motion carried.

**Approval Of Minutes - August 19, 2019**

Comm. Christianson motioned to approve the minutes. Comm. Bostwick seconded, and the motion carried.

**General Items**

D. Fry and J. Goodman provided an update on the progress of the Veterans Park Pavilion project.

**2019 Work Plan**

**a. Update, Discussion, And Possible Action On Story Gardens Project At The Milton Public Library**

Director Cushman provided an update on the Story Gardens Project.

**Update On Painting Of Goodrich Square Splash Pad**

Director Cushman stated staff is recommending to the Common Council at the September 17, 2019 meeting to use funds from the 2019 budget to repaint the splash pad to slip and mildew resistance. If approved, the work will be completed in the fall of 2019.

**Discussion On How Park Fund Dollars Can Be Used**

Director Robinson provided an overview of how the Park Fund dollars can be used.

**Discussion And Possible Action On 2020 Work Plan**

The commission developed a list of items to include in their 2020 Work Plan. Director Cushman will create the 2020 Work Plan with the discussion items from the meeting and present for final approval at the next meeting.

**General Items**

Director Robinson provided an update on the construction of Water Tower Park.

Comm. Bostwick asked for the list of items to be fixed from the park surveys that were done by commissioners previously. Director Cushman will provide this at the next meeting.

**Set Next Meeting Date**

The next meeting of the Parks & Recreation Commission will take place on October 21, 2019 at 6 p.m.

**Motion To Adjourn**

Comm. Bostwick motioned to adjourn the September 16, 2019 meeting of the Parks & Recreation Commission at 7:13 p.m. Comm. Christianson seconded, and the motion carried.

Respectfully Submitted,

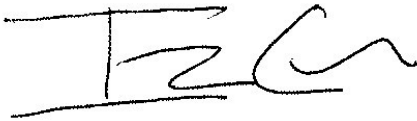
A handwritten signature in black ink, appearing to read 'I. Cushman', written over a horizontal line.

Inga Cushman  
Administrative Services Director



S12824 COUNTY ROAD U  
 STRUM, WI 54770  
 (715)214-5862  
 ruth@bdexhibits.com

# Estimate

**ADDRESS**

MILton Public Library  
 430 E. High Street  
 Milton, Wisconsin 53563

**SHIP TO**

53563

**ESTIMATE #** BD13902

**DATE** 11/04/2019

**EXPIRATION DATE** 12/05/2019

**REP**

SB

**REF #**

Ashlee Kunkel

| ACTIVITY   | QTY | RATE   | AMOUNT   |
|--|-----|--------|----------|
| ALUMINUM POST MOUNTED FRAMES   |     |        |          |
| <b>SWPWP182445B</b>  | 17  | 302.82 | 5,147.94 |
| STORYWALK ALUMINUM FRAME FOR PANEL 18H X 24W X 1/4" THICK, 5/16" GAP, BOTTOM REMOVABLE RAIL WITH RIVNUT CONSTRUCTION, AND (1) 3X3X60" POST W/PLATE, 45 DEGREE ANGLE, IN GROUND INSTALLATION, INCLUDES (2) PCS ACRYLIC, BLACK TEXTURE POWDERCOAT [SWPWP182445B] |     |        |          |
| <b>DISCOUNT</b>  | 17  | -30.28 | -514.76  |
| DISCOUNT FOR ITEMS ABOVE   |     |        |          |
| <b>S&amp;H</b>   | 1   | 476.00 | 476.00   |
| ESTIMATED SHIPPING AND HANDLING - NO SPECIAL SERVICES INCLUDED - DELIVERY TO COMMERCIAL ADDRESSES ONLY   |     |        |          |
| IF SPECIAL SERVICES SUCH AS LIFTGATE OR DELIVERY APPTS ARE NEEDED, WE ARE UNABLE TO EXPEDITE TRANSIT AND CANNOT GUARANTEE A REQUESTED DELIVERY DATE  |     |        |          |
| <b>SW-FRT</b>  | 1   | 0.00   | 0.00     |
| ALL OR SOME OF THE FOLLOWING ACCESSORIAL SERVICES MAY APPLY DEPENDING ON DELIVERY ADDRESS:<br>LIMITED ACCESS CHARGE<br>LIFTGATE SERVICE<br>RESIDENTIAL DELIVERY - TRUCK SHIPMENT<br>NOTIFY BEFORE DELIVERY   |     |        |          |
| DELIVERY CAPABILITIES MUST BE VERIFIED AT TIME OF ORDER  |     |        |          |
| <b>SW-TERMS</b>  | 1   | 0.00   | 0.00     |
| TERMS ARE 50% DOWN PAYMENT WITH SIGNED ESTIMATE, BALANCE NET 10 DAYS AFTER SHIPPING<br>ALTERNATIVE TERMS MAY BE AVAILABLE THROUGH DISCUSSION WITH BDID MANAGEMENT  |     |        |          |

REMIT PAYMENT TO: BARKING DOG INTERPRETIVE DESIGN INC., S12824 COUNTY ROAD U, STRUM WI 54770 | REMIT PAYMENT TO:  
 BARKING DOG INTERPRETIVE DESIGN INC., S12824 COUNTY ROAD U, STRUM WI 54770

| ACTIVITY | QTY | RATE | AMOUNT |
|----------|-----|------|--------|
|----------|-----|------|--------|

**SW-NOTE**

PAGE DISPLAY SUGGESTION: USE 10 MIL HOT LAMINATE TO ENCLOSE THE BOOK PAGE OR PRINTED PAGE WHICH HAS BEEN BACKED WITH COLORED PLASTIC BACKER. THERE SHOULD BE 1/8" EDGE OF LAMINATE SURROUNDING ALL 4 SIDES OF THE STOCK. PAGES SHOULD BE PLACED BETWEEN THE 2 SHEETS OF ACRYLIC, THEN INSTALLED INTO THE FRAME. DURING SEASONS WITH HIGH HUMIDITY OR RAIN, CONDENSATION OR MOISTURE MAY OCCUR BETWEEN ACRYLIC SHEETS.

1

0.00

0.00

FOR QUESTIONS REGARDING ESTIMATES CONTACT RUTH AT  
ruth@bdexhibits.com

TOTAL

**\$5,109.18**

TO PLACE YOUR ORDER SEND A COPY OF THIS SIGNED ESTIMATE  
TO kim@bdexhibits.com

Accepted By

Accepted Date



S12824 COUNTY ROAD U  
 STRUM, WI 54770  
 (715)214-5862  
 ruth@bdexhibits.com

# Estimate

**ADDRESS**

MILton Public Library  
 430 E. High Street  
 Milton, Wisconsin 53563

**SHIP TO**

53563

**ESTIMATE #** BD13903

**DATE** 11/04/2019

**EXPIRATION DATE** 12/05/2019

**REP**

SB

**REF #**

Ashlee Kunkel

| ACTIVITY  | QTY | RATE   | AMOUNT   |
|---|-----|--------|----------|
| CUSTOMER'S WOOD POST, ANGLE MOUNTED FRAMES  |     |        |          |
| <b>SW-1824-45B</b>  | 17  | 234.20 | 3,981.40 |
| STORYWALK ALUMINUM POST MOUNT FRAME FOR PANEL 18H X 24W X 1/4" THICK, 5/16" GAP, 45 DEGREE ANGLE, (1) POST MOUNT WITH (2) THRU HOLES TO ATTACH TO CUSTOMER 4X4 WOOD POST WITH PROVIDED SPAX SCREWS, TWO PART CONSTRUCTION, BOTTOM REMOVABLE RAIL WITH RIVNUT CONSTRUCTION, INCLUDES (2) 18"X24" PIECES OF ACRYLIC, BLACK TEXTURE POWDERCOAT [SW-1824-45B] |     |        |          |
| <b>DISCOUNT</b>   | 17  | -23.40 | -397.80  |
| DISCOUNT FOR ITEMS ABOVE  |     |        |          |
| <b>S&amp;H</b>  | 1   | 340.00 | 340.00   |
| ESTIMATED SHIPPING AND HANDLING - NO SPECIAL SERVICES INCLUDED - DELIVERY TO COMMERCIAL ADDRESSES ONLY - LTL  |     |        |          |
| <b>SW-FRT</b>   | 1   | 0.00   | 0.00     |
| ALL OR SOME OF THE FOLLOWING ACCESSORIAL SERVICES MAY APPLY DEPENDING ON DELIVERY ADDRESS:<br>LIMITED ACCESS CHARGE<br>LIFTGATE SERVICE<br>RESIDENTIAL DELIVERY - TRUCK SHIPMENT<br>NOTIFY BEFORE DELIVERY<br><br>DELIVERY CAPABILITIES MUST BE VERIFIED AT TIME OF ORDER   |     |        |          |
| <b>SW-TERMS</b>   | 1   | 0.00   | 0.00     |
| TERMS ARE 50% DOWN PAYMENT WITH SIGNED ESTIMATE, BALANCE NET 10 DAYS AFTER SHIPPING<br>ALTERNATIVE TERMS MAY BE AVAILABLE THROUGH DISCUSSION WITH BDID MANAGEMENT   |     |        |          |
| <b>SW-NOTE</b>  | 1   | 0.00   | 0.00     |
| PAGE DISPLAY SUGGESTION: USE 10 MIL HOT LAMINATE TO ENCLOSE THE BOOK  |     |        |          |

REMIT PAYMENT TO: BARKING DOG INTERPRETIVE DESIGN INC., S12824 COUNTY ROAD U, STRUM WI 54770 | REMIT PAYMENT TO:  
 BARKING DOG INTERPRETIVE DESIGN INC., S12824 COUNTY ROAD U, STRUM WI 54770

ACTIVITY

QTY

RATE

AMOUNT

PAGE OR PRINTED PAGE WHICH HAS BEEN BACKED WITH COLORED PLASTIC BACKER. THERE SHOULD BE 1/8" EDGE OF LAMINATE SURROUNDING ALL 4 SIDES OF THE STOCK. PAGES SHOULD BE PLACED BETWEEN THE 2 SHEETS OF ACRYLIC, THEN INSTALLED INTO THE FRAME. DURING SEASONS WITH HIGH HUMIDITY OR RAIN, CONDENSATION OR MOISTURE MAY OCCUR BETWEEN ACRYLIC SHEETS.

FOR QUESTIONS REGARDING ESTIMATES CONTACT RUTH AT  
ruth@bdexhibits.com

TOTAL

**\$3,923.60**

TO PLACE YOUR ORDER SEND A COPY OF THIS SIGNED ESTIMATE  
TO kim@bdexhibits.com

Accepted By

Accepted Date





# StoryWalk® Solutions

## ALUMINUM FRAME AND ALUMINUM POST - ANGLED

For a 18" h x 24" w page, with a viewable area of 17" h x 23" w.

45 degree display angle.

Standard post length is 60", for in ground installation

Longer posts and surface mounted posts are available.

Installed height 28" to 32"

Prepare footing depth per your region's requirements.

Ensure post is plumb and level while back filling with appropriate material.

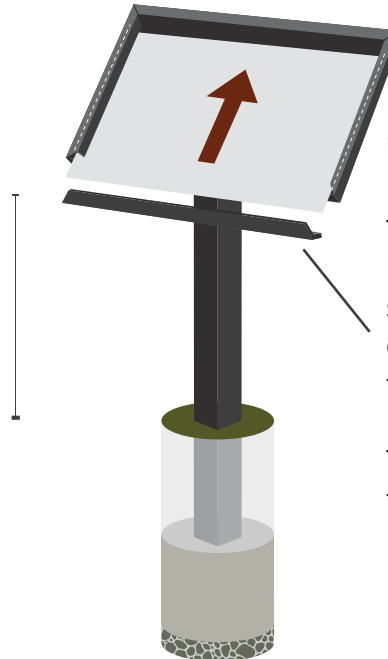

Removable bottom rail for page insertion.

The 2 sheets of acrylic - with the laminated page between them - slide up into the exposed channel on the bottom of the frame.

The powder coated aluminum frame has a 1 year warranty.

Made in the USA!

### Assembly Instructions

1. Install the frame to the sleeve with the (4) allen head screws, one flat washer, and one nylock nut. The allen driver is provided, you will need a 7/16" socket to install the nylock nut. Do not use power tools as stainless steel hardware will gall and seize.

2. Remove the bottom frame rail 2 screws with the allen driver. Holding the rail in your hand, install a screw thru the rail, then push a white retaining washer down over the threads. Repeat. The retaining washer will help keep the screws in the frame rail which you replace pages.

### Page Installation – first time

1. Remove the blue masking from both sides of the acrylic.
2. Place your page and optional colored backer between the sheets of acrylic. Be sure your pages are numbered, or you know what page order they should be installed.
3. Remove the bottom frame rail using the provided driver.
4. Slide the sheets up into the exposed frame channel.
5. Replace the bottom rail.

### Cleaning Instructions

Use a soft cloth and dilute soap and water to wash and dry the displays.

DO NOT USE ammonia cleaners (Windex) or paper towels.

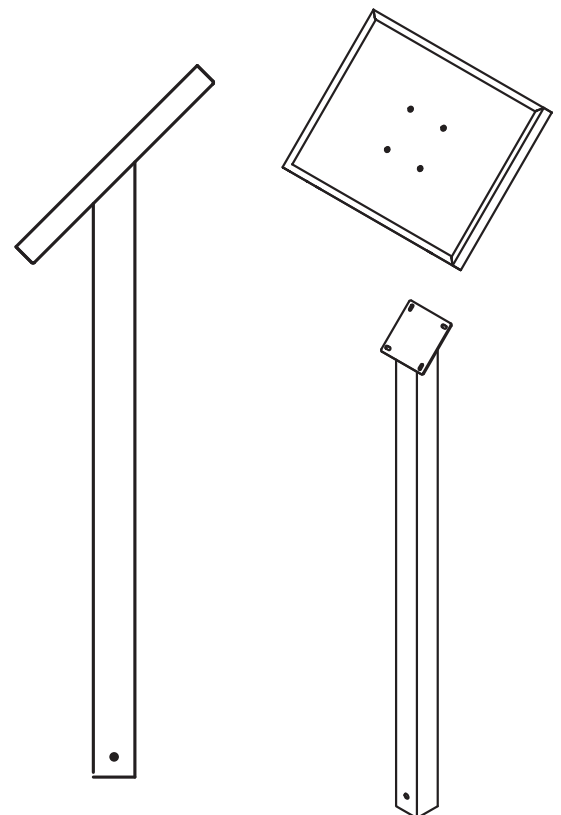



# StoryWalk® Solutions

## FRAME WITH SLEEVE FOR YOUR WOOD POST - ANGLED

Aluminum sleeve is mechanically attached to the frame. Sleeve fits over a 4x4 wood post, cut at 45 degree display angle. Post is approx. 3.5"x3.5"

For a 18"h x 24"w page, with a viewable area of 17" h x 23" w.

Can install to recycled lumber posts 3.5"x3.5"x60"

Installed height 28" to 32"

Prepare footing depth per your regions requirements.  
Ensure post is plumb and level while back filling with appropriate material.  
Option if not using concrete – drill a 9/16" hole at 2" from the base of the post. Install 8" of rebar into the hole.

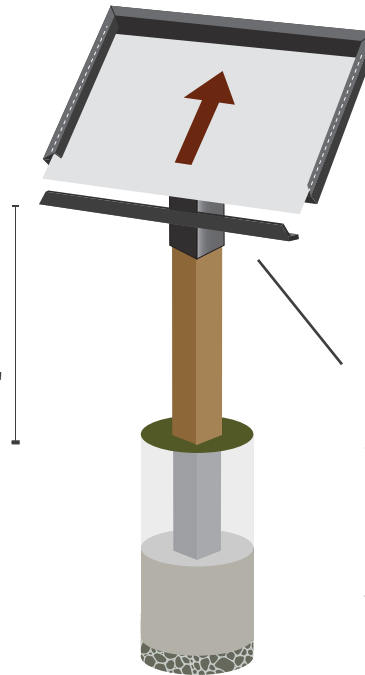

Removable bottom rail for page insertion.

2 sheets of acrylic - with the laminated page between them - slide up into the exposed channel of on the bottom of frame.

The powder coated aluminum frame has a 1 year warranty.

Made in the USA!

### Assembly Instructions

1. To make TWO 60" long posts, mark the center point of a 10' long treated 4x4. With a speed square, mark a 45-degree cut line on each post side. Cut in half, on the 45, with a circular saw.
2. Drill a 9/16" thru hole for 8" of rebar, if desired.
3. Install the sleeve assembly to the post using the (2) SPAX screws and the provided SPAX driver.
4. Install the frame to the sleeve with the (4) allen head screws, (1) flat washer, and (1) nylock nut. The allen driver is provided, you will need a 7/16" socket to install the nylock nut. Do not use power tools as stainless steel hardware will gall and seize.
5. Last, remove the bottom frame rail 2 screws with the allen driver. Holding the rail in your hand, install a screw thru the rail, then push a white retaining washer down over the threads. Repeat. The retaining washer will help keep the screws in the frame rail which you replace pages.

### Page Installation – first time

1. Remove the blue masking from both sides of the acrylic.
2. Place your page and optional colored backer between the sheets of acrylic. Be sure your pages are numbered.
3. Remove the bottom frame rail using the provided driver.
4. Slide all the sheets up into the exposed channel in the frame.
5. Replace the bottom rail.

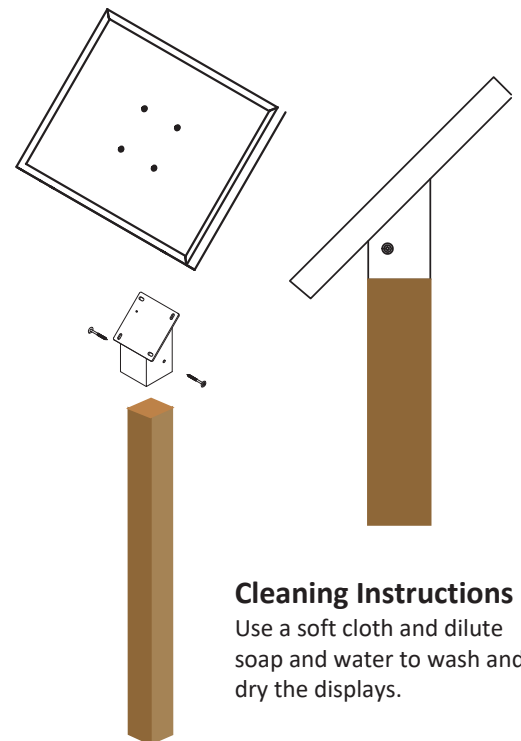

### Cleaning Instructions

Use a soft cloth and dilute soap and water to wash and dry the displays.

DO NOT USE ammonia cleaners (Windex) or paper towels.



# City of Milton

## Parks & Recreation Commission

---

### 2020 Work Plan

#### MISSION

The Parks and Recreation Commission oversees development of new, and maintenance of existing, indoor and outdoor recreational facilities owned by the City of Milton. The commission strives to provide quality recreation opportunities at city parks and facilities that serve people of all ages and abilities.

#### 2019 PROJECT REVIEW

- Crossridge Park
  - Hosted the Annual Prairie Seed Collection – October 19, 2019
- Tree City USA Designation
  - Recommended approval of the Arbor Day Proclamation to the Common Council – March 18, 2019
  - Hosted an Arbor Day Observance event
  - Completed the application for Tree City USA Designation
  - Recommended approval to the Common Council of a resolution authorizing the submittal of an Urban Forestry Grant from the Wisconsin Department of Natural Resources.
  - Received a 2019 Urban Forestry Grant from the Wisconsin Department of Natural Resources.
  - Continued current tree replacement program in parks.
- Milton Area Veterans Memorial
  - Placed additional bricks at the memorial
  - Assisted with the 2<sup>nd</sup> Annual Active Duty Military Honor Holiday Tree
  - Worked with volunteers on fundraising, planning, and construction of a pavilion at Veterans Park.
- Bike Racks
  - Purchased two bike racks – One at North Goodrich Park and one at South Goodrich Park. Installation will occur in the fall of 2019 or spring of 2020, depending on weather and staff schedules.
- King Park
  - Determined the locations for two new baskets that will be added in the fall of 2019 or spring of 2020, depending on weather and staff schedules.
- Tails n Trails Dog Park
  - Hosted Annual Clean Up on September 14, 2019.
- Tower Hill Park Improvements
  - Added a path to the playground equipment from the sidewalk for accessibility.
- Water Tower Park
  - Purchased and installed additional playground equipment at the park.

## **2020 PARKS & RECREATION COMMISSION PLANNED PROJECTS AND ACTIVITIES**

- Bike Racks
  - Select locations, purchase, and install two new bike racks for City of Milton parks.
- Community House Rejuvenation
  - Develop a plan of action to rejuvenate the Community House interior and exterior.
- Lamar Park
  - Blacktop under bleachers at the “little” ball diamond.
- Liberty Park Updates – Play and Traffic
  - Select, purchase, and install additional playground equipment to enhance play opportunities at the park.
  - Analyze options to create a safer traffic pattern in and out of the park.
- Milton Area Veterans Memorial / Veterans Park
  - Continue Annual Active Duty Military Honor Holiday Tree.
  - Place bricks at the memorial prior to Memorial Day, 4<sup>th</sup> of July, and Veterans Day.
  - Host the dedication of the Veterans Park Pavilion on Memorial Day, May 25, 2020.
  - Determine the locations in the park and plant a mix of evergreens and shade trees.
- Milton Public Library Outdoor Space – Story Gardens
  - Continue work on the design, fundraising, and construction.
  - Construct a gazebo, raised garden beds, and ramp if funding is in place.
- Pollinator Art
  - Work with the schools and/or local artists on creating art pieces that showcase pollinators for Crossridge Park and/or Story Gardens at the Milton Public Library.
- Tails n Trails Dog Park
  - Host Annual Clean Up – April 25, 2020
  - Determine new location for the port-a-john away from the entrance and blacktop a spot for it to maintain a level surface.
  - Add a curb around the dog washing station to better direct the water flow away from the parking lot.
- Trail connecting Crossridge Park to Schilberg Park
  - Continue discussions on this project as shown in the Comprehensive Plan as development in the area continues.
- General park maintenance as documented in previous park surveys.
- Review the lights at the ball diamonds and make repairs as needed.
- Create a video catalog of the parks with assistance from an Eagle Scout or high school students, if possible.
- Tree City USA Designation

- Recommend approval of the Arbor Day Proclamation to the Common Council
- Host an Arbor Day Observance event – April 25, 2020
- Complete application for Tree City USA Designation
- Recommend approval to the Common Council of a resolution authorizing the submittal of a 2021 Urban Forestry Grant from the Wisconsin Department of Natural Resources.
- Continue current tree replacement program in parks.

**MILTON PARKS & RECREATION COMMISSION MEMBERS**

|  |   |
|--|---|
| Ryan Peterson, Chairperson                       | Ald. Jerry Elsen  |
| James Bostwick                                   | Andrea Christianson                                       |
| Lee Ann Hare                                     | Karen Reed  |
| Annette Smith                                    | David Snow  |
| Ty Knudsen, Milton High School<br>Representative | Howard Robinson, Director of Public Works<br>(Ex-Officio) |